

CARACTERISTICAS GENERALES	
CÓDIGO DE PALLET:	PP003BTS
MADERA:	EUCA
PESO (kg. +/- 10%):	34
PIES CUADRADOS:	16,98
ZORRA HIDRÁULICA:	APTO
CDAD DE ENTRADAS:	4
HUMEDAD:	-
APILADO:	25

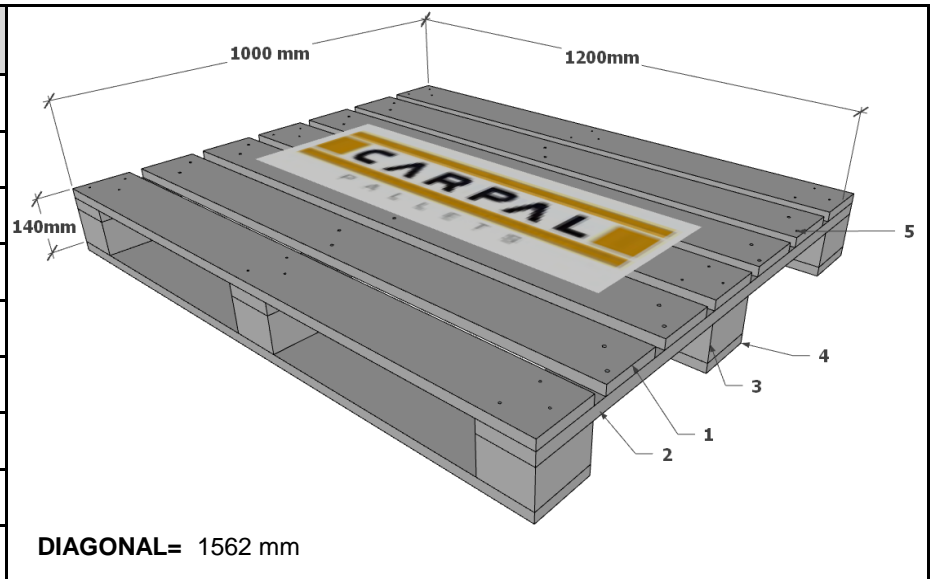

Ref	Cantidad	Código	Medidas (mm)	Tolerancias	Descripción
1	7	ME0201001200CNN	20 x 100 x 1200	1,5	Tabla de Eucalipto Cepillada
2	3	ME0251001000CNN	25 x 100 x 1000	1,5	Tabla de Eucalipto Cepillada
3	9	ME0751000100CNN	75 x 100 x 100	1,5	Taco de Eucalipto Cepillada
4	3	ME0251001200CNN	25 x 100 x 1200	1,5	Tabla de Eucalipto Cepillada
5	105	CE25-63R	105	s/e	Clavo Espiralado en Rollo

SELLADO		CLAVADO												
<p>El sello "AR-00000 HT" debe estar en el taco izquierdo de la cara, apuntando sus flechas hacia el centro del pallet.</p> 	<p>El sello numérico "1346290319" debe estar en el taco derecho de la misma cara del sello "AR-00000 HT".</p> 													
		<table border="1"> <thead> <tr> <th>Partes clavadas</th> <th>Tipo de clavo</th> <th>Cantidad c/u</th> </tr> </thead> <tbody> <tr> <td>Patin - Taco</td> <td rowspan="4">CE25-63R</td> <td>3</td> </tr> <tr> <td>Conectora - Taco</td> <td>3</td> </tr> <tr> <td>Conectora - Parrilla</td> <td>2</td> </tr> <tr> <td>Parrilla - Conectora - Taco</td> <td>3</td> </tr> </tbody> </table>	Partes clavadas	Tipo de clavo	Cantidad c/u	Patin - Taco	CE25-63R	3	Conectora - Taco	3	Conectora - Parrilla	2	Parrilla - Conectora - Taco	3
Partes clavadas	Tipo de clavo	Cantidad c/u												
Patin - Taco	CE25-63R	3												
Conectora - Taco		3												
Conectora - Parrilla		2												
Parrilla - Conectora - Taco		3												
 <p>Sellar en pallet en ambas caras de 1200 mm. Cantidad total de sellos = 4.</p>		<p align="center">ACLARACIONES EXTRAS</p> <p align="center">Sin aclaraciones extras.</p>												