

CARACTERISTICAS GENERALES	
CÓDIGO DE PALLET:	PP006LTS
MADERA:	EUCA
PESO (kg. +/- 10%):	35
PIES CUADRADOS:	17,66
ZORRA HIDRÁULICA:	APTO
CDAD DE ENTRADAS:	4
HUMEDAD:	-
APILADO:	29 E

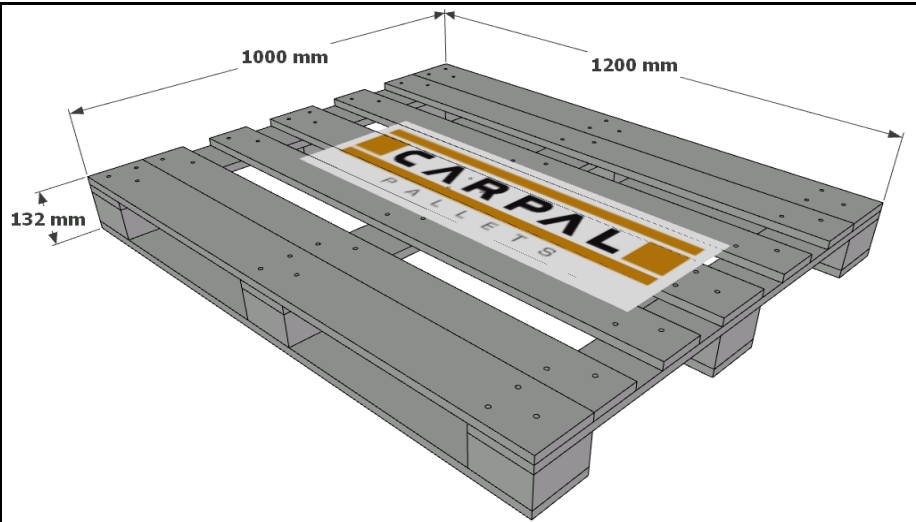

DIAGONAL= 1562 mm

Ref	Cantidad	Código	Medidas (mm)	Tolerancias	Descripción
1	3	ME0191201200NNN	19 x 120 x 1200		Tabla de eucalipto
2	4	ME0190951200NNN	19 x 95 x 1200		Tabla de eucalipto
3	3	ME0191201000NNN	19 x 120 x 1000		Tabla de eucalipto
4	9	ME0751200120NNN	75 x 120 x 120		Taco de eucalipto
5	3	ME0191201200NNN	19 x 120 x 1200		Tabla de eucalipto
6	24	CA26-39S	2,6 x 39		Clavo anillado suelto
7	27	CE25-50S	2,5 x 50		Clavo espiralado suelto
8	27	CE29-75S	2,9 x 75		Clavo espiralado suelto

SELLADO		CLAVADO		
<p>El sello "AR-00000 HT" debe estar en el taco izquierdo de la cara, apuntando sus flechas hacia el centro del pallet.</p>  <p>El sello numérico "1346290319" debe estar en el taco derecho de la misma cara del sello "AR-00000 HT".</p>   <p>Sellar en pallet en ambas caras de 1200 mm. Cantidad total de sellos = 4.</p>	Partes clavadas		Tipo de clavo	Cantidad c/u
	Patin - Taco		CE26-63S	3
	Conectora - Taco		CE25-63S	3
	Conectora - Parrilla		CA26-39S	2
ACLARACIONES EXTRAS				
Sin aclaraciones extras.				